

CAD FILE:

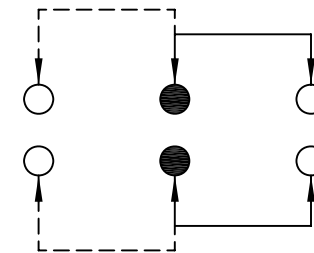

SCHEMATIC (MON-SHORTING)

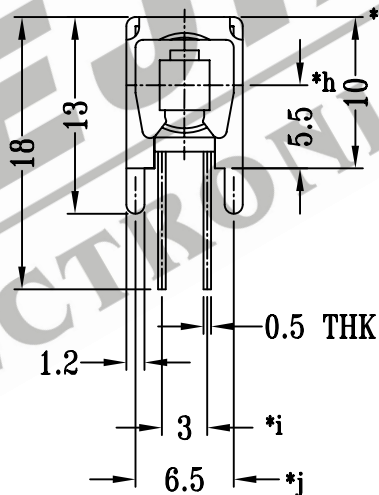
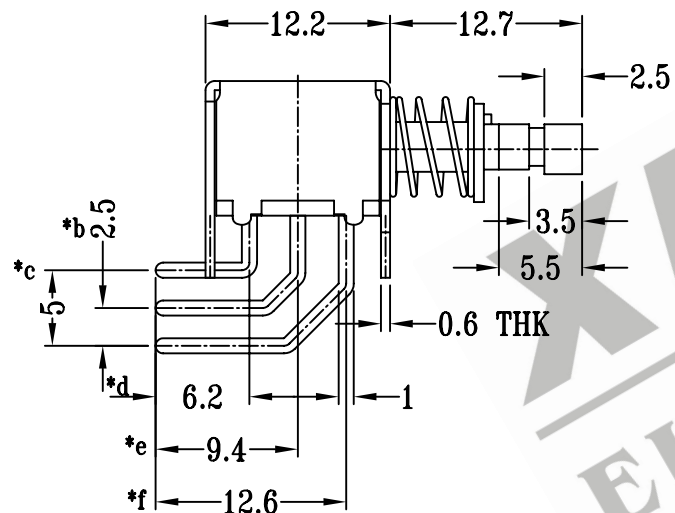
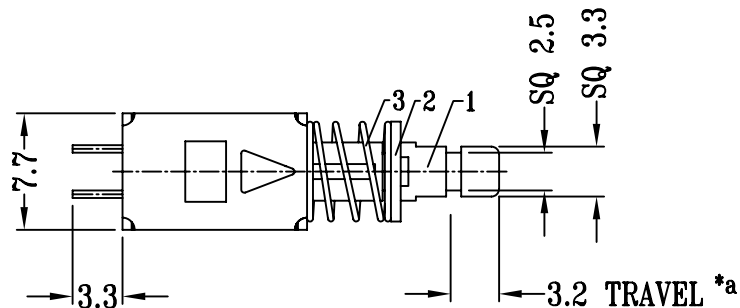
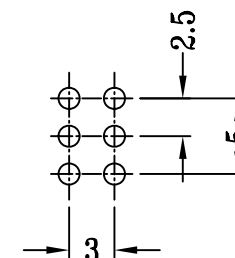

P.C.B LAYOUT

注:带"*"表示关键尺寸(10个)

8	CONTACT CLIP	PBS STRIP	2	Ag PLATED	TOLERANCE UNLESS SPECIFIED	SHENZHEN XIEJIA ELECTRONICS CO.,LTD.				
7	TERMINAL	BRASS STRIP	6	Ag PLATED OVER Ni PLATED						
6	BASE	PHENOLIC RESIN	1	NATURAL	WITHIN: 1.5±0.1mm OVER: 1.5±0.2mm	ISSUE	DATE	DESCRIPTIONS OF REVISION		APPD.
5	FRAME	STEEL STRIP	1	Ni PLATED						
4	SCREEN	STEEL STRIP	1	Ni PLATED	TITLE : PUSH SWITCH		UNIT : mm	DRWG NO.: XJ-DR-PS22F33-00		
3	SPRING	STEEL WIRE	1	Ni PLATED	MODEL: PS-22F33 (NON-LOCKED)		SCALE: 2 : 1	DWN.	ZHOUYU	2004-9-6
2	BLOCK	STEEL STRIP	1	Ni PLATED	ALL MATERIALS MUST BE COMPLIANT TO ROHS			CHK'D	FANGYING	2004-9-6
1	KNOB	POM	1	BLACK			APPD.	KANGXINAN	2004-9-6	
NO.	PARTS	MATERIALS	Q'TY	FINISH						